

# Hyperchill BioEnergy

## Water Chillers for Biogas and Biomethane Gas Cooling Applications



Bioenergy is renewable energy stored in organic materials such as plant matter and animal waste, known as biomass. The wide variety of biomass fuel sources include agricultural residue, pulp/paper mill residue, urban wood waste, forest residue, energy crops, landfills and animal waste. Anaerobic digestion is the process that occurs when bacteria decompose organic materials in the absence of oxygen to generate biogas.

Biogas is primarily composed of methane and carbon dioxide with smaller amounts of hydrogen sulphide and ammonia. Trace amounts of other gases like hydrogen, nitrogen or carbon monoxide are also present in the biogas. Usually the mixed gas is saturated with water-vapour and may contain dirt particles. For biogas as a fuel, most of the impurities have to be removed, as they can cause contamination, deposits and damage to equipment. In particular, biogas needs to be dried by cooling it to temperatures close to 5°C, using water-cooled heat exchangers fed by water chillers. Hyperchill BioEnergy is a key component in this biogas treatment process.

Extremely compact and easy to use, Hyperchill BioEnergy ensures an accurate control of the water temperature. It has been specifically designed for Biogas applications and provides safe and reliable operation in the harshest of environments, typically found in Anaerobic Digesters and landfill Biogas production areas.



### Benefits

- Special protective treatment of condensers and copper piping to ensure reliable operation in the most aggressive of ambient atmospheres at biogas plants and landfill sites.
- Pump and tank installed inside the chiller provides a compact and easy to install solution.
- Precise water temperature control with high working limits and low running costs.
- Non-ferrous hydraulic circuit on ICEP-E range enhances the reliable operations maintaining the quality of the coolant ensuring stable working conditions.
- Large built-in water tank that provides a large thermal mass/storage capacity thus reducing the number of refrigerant compressor stop/starts and short cycling and thereby increasing the compressor and chiller lifetime.
- Designed to provide cooling water where low temperature water is required as standard (air conditioning units do not normally need to provide water at less than 10°C).
- Use of compliant scroll compressors designed specifically for high efficiency and long life in industrial applications.
- Eco friendly design according to F-Gas 2024/573:
  - Use of R513A non-flammable refrigerant (GWP 629, Safety Class A1) on ICEP-E models.
  - Use of R1234ze refrigerant (GWP 1,37, Safety Class A2L) on ICES-E models, which is considered non-flammable for transporting and storage purposes.
- Low ambient speed-control on fan-motor ensures constant performances at different temperatures, and a reduction in absorbed power when ambient temperature is low.
- Maximum working ambient temperature up to 48°C, prevents downtime even under extremely harsh conditions.



ENGINEERING YOUR SUCCESS.

# Hyperchill BioEnergy

The performance of biogas as a fuel depends on effective cooling and treatment.

Saturated biogas contains water and impurities that need to be removed to avoid damage to equipment and to reach more efficient combustion, whilst maintaining the desired dew point.

## Product Features

- **Water and refrigerant manometers** permit full control of the working conditions.
- **Microprocessors:** allow complete control of the unit parameters. Proprietary software provide a wide range of programming and remote monitoring options.
- **Compliant scroll compressors:** with less moving parts and compliant technology, they provide excellent efficiency, high reliability, and very low noise levels.
- **Air cooled with axial fans:** suitable for outdoor installation.
- **Water pump:** available with different head pressures to suit the end-users application. Configurable as a twin-system, for 100% redundancy.
- **Mesh filters:** condenser protection against dirt and contamination, reduces maintenance costs and the risk of downtime.



- **Evaporator:** specifically designed for operation with new low GWP refrigerants, increasing chiller reliability and efficiency.
- **Water by-pass:** protects the pump and supplies constant flow to the evaporator, avoiding alarms and freezing.
- **Water tank:** generously sized to guarantee high reliability and improved temperature control, available on all models, in stainless steel up to ICEP120E.
- Models from ICEP022E are designed with **fan control** to work as standard in low ambient temperatures down to -10°C.
- **Maximum ambient temperature** up to 48°C on all sizes.
- **MODBUS interface** fitted on all sizes (RTU on ICEP-E range, RTU & TCP/IP on ICES-E range).
- **Bioenergy protection:** All exposed aluminum and copper parts are epoxy coated to prevent corrosion of the refrigerant copper piping and condensers

## Options and Accessories

- **Special and multiple-pumps:** higher head pressure available to suit different hydraulic circuits. Double stand-by pump for greater reliability.
- **Antifreeze heating:** avoids freezing when the unit is switched off. Can also be used as a heater to warm up the system.
- **Water fill-kits:** pressurized, automatic or ambient manual kits, for water filling in any installation.
- **Remote control kits:** base version for remote ON/OFF and general alarm monitoring. Advanced version for complete remote unit management.
- **Wheels (up to ICEP015E BioEnergy):** for ease of transport.
- **Control panel cover:** for additional display protection from aggressive ambient.



# Technical Data

Model		ICEP-E											ICES-E							
		008E	011E	015E	022E	027E	034E	041E	055E	065E	080E	100E	120E	160E	200E	240E	320E	400E	470E	580E
Cooling capacity <sup>1</sup>	kW	7,8	11,1	15,0	21,9	26,6	33,1	40,2	56,3	65	78,3	103,7	120,6	161.2	187.5	236.2	320.3	390.2	472.8	586
Total abs. power <sup>1</sup>	kW	1,6	2,3	3,6	5,0	5,7	6,7	8,3	12,8	15,3	18,5	24,2	29,8	31,7	41,1	52,6	68,1	78,9	103,4	123,4
SEPR HT <sup>2</sup>		5,34	5,40	5,01	5,50	5,20	5,60	5,33	5,06	5,10	5,20	5,10	5,02	5,8	5,29	5,20	5,45	5,58	5,31	5,50
Cooling capacity <sup>3</sup>	kW	4,5	6,5	8,8	12,7	14,9	18,2	22,6	32,0	36,9	44,8	60,4	72,1	90,2	107,2	133,1	181,5	218,9	306,8	330,5
Tota abs. power <sup>3</sup>	kW	1,6	2,4	3,7	5,0	6,0	7,3	9,0	13,7	16,0	19,3	24,7	29,0	33,2	42,8	53,6	69,8	81,7	109,2	124,0
Power Supply	V/ph/Hz	400/3/50											400/3/50							
Protection index		IP54											IP54							
Refrigerant		R513A											R1234ze							

## Compressor

Type	hermetic scroll											hermetic scroll						
Compressors/circuit	1/1					2/1		2/2				2 / 2			4 / 2			

## Axial fans

Quantity	no.	1			2				3			2	3	4	6	8		
Air flow	m <sup>3</sup> /h	3325	3325	5028	7823	10865	17337	17057	17057	17110	26832	26082	26082	39959	57702	76889	115333	153778

## Weights and Dimensions

Width	mm	756	756	756	756	756	856	856	856	856	1050	1050	1050	1400	1400	1400	2150	2150	2150	2150
Depth	mm	806	806	806	1206	1206	1956	1956	1956	1956	2500	2500	2500	3540	3540	3540	3500	3500	3500	4580
Height	mm	1430	1430	1430	1430	1430	1680	1680	1680	1680	2012	2012	2012	2220	2220	2220	2480	2480	2480	2480
Connections in/out	in	¾"	¾"	¾"	1"	1"	1½"	1½"	1½"	1½"	2"	2"	2"	2½"	2½"	2½"	Victaulic DN100 4"			
Total water storage capacity (with tank)	l	65	65	65	100	100	200	200	200	200	400	400	400	950	950	950	500	500	500	500
Weight (axial) <sup>4</sup>	kg	165	175	180	235	250	485	510	580	595	875	1010	1030	1600	1800	1850	2530	2880	3200	4000

## Noise level

Sound pressure	dB(A)	50	50	51	52	52	53	54	55	55	58	59	59	62	62	65	65	65	68	68
----------------	-------	----	----	----	----	----	----	----	----	----	----	----	----	----	----	----	----	----	----	----

- 1) At water in/out temperature 20/15°C, glycol 0%, either 25°C ambient temperature.
- 2) Value calculated in accordance with the European regulation (EU) 2016/2281 with regards to Ecodesign requirements for high temperature process chillers
- 3) At water in/out temperature 5/1°C, glycol 10%, ambient temperature 35°C.
- 4) Includes refrigerant charge and pallet (version without options and accessories).
- 5) Sound pressure: average value obtained in free field on a reflective surface at a distance of 10 m from the condensate side of the machine and at a height of 1.6 m from the unit support base. Values with tolerance ± 2 dB. The sound levels refer to operation of the unit under full load in nominal conditions.

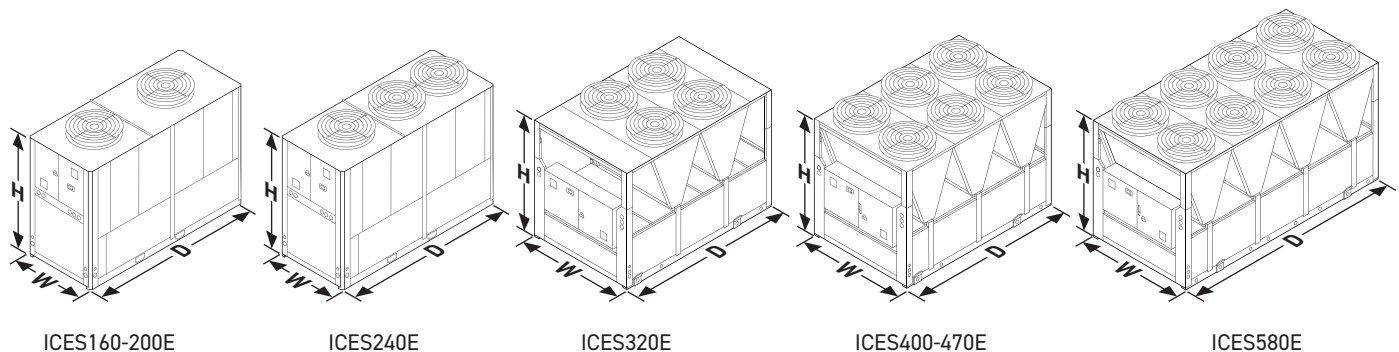
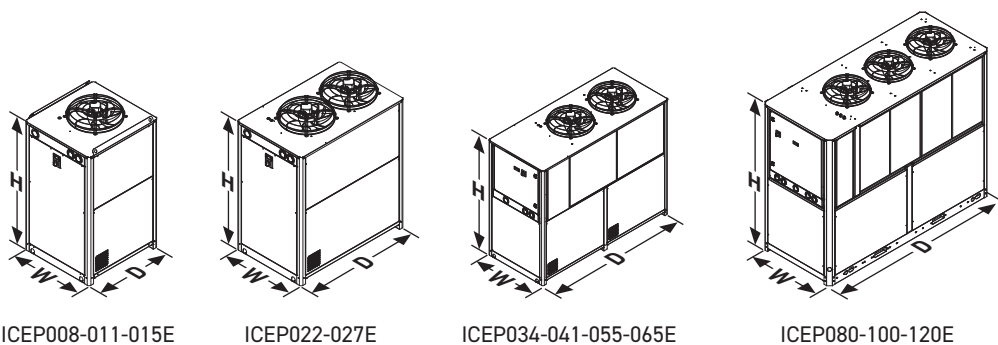

## Service & underhåll

En viktig del i vårt koncept som totalleverantör och partner, är att kunna erbjuda kvalificerad specialthjälp för tillsyn, service och underhåll av kompressorer, tryckluftsanläggningar och gasgeneratorer. Genom att teckna serviceavtal med oss, kommer kvalificerad service, rätta reservdelar, effektiva rutiner och löpande dokumentation att garantera en säkrare drift och användning för att distribuera ren tryckluft och rätt kvävgaskvalitet.



### ISO 14001

Granzow service är certifierad enligt ISO 14001 vilket medför att kvalitets- och miljötänkande är naturliga faktorer i vårt arbete. Vi ser som en av våra uppgifter att hålla våra kunders tryckluftsproduktion igång och samtidigt utföra uppdraget med utgångspunkt från högt ställda kvalitets- och miljökrav.



Rätt kapacitet



Rätt kvalitet



Rätt tryck



Rätt service

# GRANZOW

svensk tryckluftspartner

Service: 020-78 80 00  
Försäljning: 0171-47 80 00  
[www.granzow.se](http://www.granzow.se)