

# Hyperfilter BioEnergy

Filters for Biogas & Landfill Gas Applications



Biogas produced in anaerobic digesters and landfills is saturated with water and contains foams, small solid particles in suspension, greases, particulates and other contaminants: it is therefore essential that these contaminants are removed from the gas by filtration prior to any downstream equipment or pipework.

Failure to remove these impurities may lead to a malfunction of devices and processes downstream and, in the absence of effective dehumidification, can cause clogging or blocking of blowers, heat exchangers and gas meters increasing maintenance costs and plant downtime.

Hyperfilter BioEnergy has been specifically designed to prevent these undesired effects, available in a range of sizes matched to the needs of biogas applications. The secret of Hyperfilter BioEnergy is its highly advanced filter element. This combines ultra-high particle retention efficiency with extremely low pressure drop which results in clean, ready to use biogas with service costs kept to a minimum.



## Features & Benefits:

- High-Efficiency filtration media which provides maximum protection for downstream equipment and pipework significantly reducing maintenance costs and plant downtime;
- Stainless steel housing materials (AISI304 or AISI316L) with pickling and passivation treatment in order to ensure highly reliable and continuous operation even in the harshest conditions typically experienced in a biogas plant or a landfill;
- Designed using fluid dynamic principles to ensure high efficiency filtration whilst maintaining a very low pressure drop;
- Range of sizes to cover biogas flow rates from 105 to 3180 m<sup>3</sup>/h (larger sizes available on request);
- Supplied complete with support legs for easy installation and mounting;
- Top access cover to enable quick and easy element replacement

# Product-Specification

## Hyperfilter BioEnergy FFB 105-3180

Hyperfilter Bioenergy is formed by a stainless steel AISI304 or AISI316L vessel with flanged cover and two flanged pipe connections for biogas inlet and outlet. The filter base acts as a trap for water and other contaminants which can then effectively removed by the manual drain valve. Two threaded etchings are provided to make possible the connection of a differential pressure gauge.

Filtration takes place through a porous filter element made of antistatic, spunbonded polyester to ensure optimum filtration efficiency and high stability. Surface electrical conductivity of the filter media is attained through the application of aluminum powders: this treatment is the best solution for all applications requiring

elimination of electrical charges created on the particles to be filtered and therefore on the filter media, in compliance with ATEX regulations.

Filtration quality is 5  $\mu\text{m}$  or 20  $\mu\text{m}$ .

### Operation

- ① The biogas enters the filter.
- ② The biogas passes through the filter element, which holds virtually all solid and liquid particles with a size higher than 5  $\mu\text{m}$  and 20  $\mu\text{m}$ .
- ③ The filtered liquid and solid particles drop to the bottom of the filter.
- ④ The filtered biogas exits the filter.

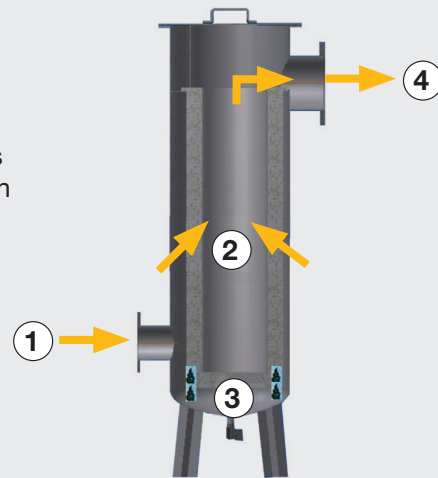

To maintain optimum and effective filtration, filter elements must be replaced at least every 6 months with genuine Parker Hiross parts. Half-year filter elements changes are therefore essential and ensure:

- Optimal performance is maintained
- High filtration quality
- Low operational costs
- Continued protection of downstream equipment & processes

Failure to perform the scheduled replacement can lead to increasing system pressure drops.

# Product-Specification

## Hyperfilter BioEnergy FFB 105-3180

### Area of Application Filter

Standard Filter	Biogas, Landfill Gas and Natural Gas
Max operating pressure	0,5 barg
Operating Temperature	-10°C up to 100°C

### Performance Data Element

Removal	Pollutants, foams, particulate and separation of residual moisture
Flow Direction	from outside to inside
Particle removal size	5 µm / 20 µm
Filtration Efficiency	99,999%
Differential pressure,dry	2 mbar

### Material housing

Housing body	Stainless steel: parts in contact with biogas in AISI304 or AISI316L, not in contact in AISI304
Surface treatment	Pickling and passivation
Gaskets	Mineral fibers with NBR binder

### Material Elements

End caps	Galvanized steel
Inner core	Perforated galvanized steel
Filter medium	260g antistatic polyester spunbonded
Sealing	Epoxy resin
Gaskets	Neoprene

A stainless steel grounding wire is mounted underneath the top ring alongside the filter medium

### Technical data and measurements

Model	Gasflow*		Connections		Filter elements
	m <sup>3</sup> /min	m <sup>3</sup> /h	IN	OUT	Quantity
FFB105	1,8	105	DN50	DN80	1
FFB265	4,4	265	DN80	DN125	1
FFB720	12,0	720	DN125	DN200	1
FFB1110	18,5	1110	DN200	DN300	1
FFB3180	41,7	2500	DN300	DN450	1

Dimensions (mm)				Weight
A	B	C	D	kg
440	1454	1330	420	32
440	1424	1300	390	35
625	1838	1595	545	99
633	1883	1650	600	108
1000	2208	1805	696	255

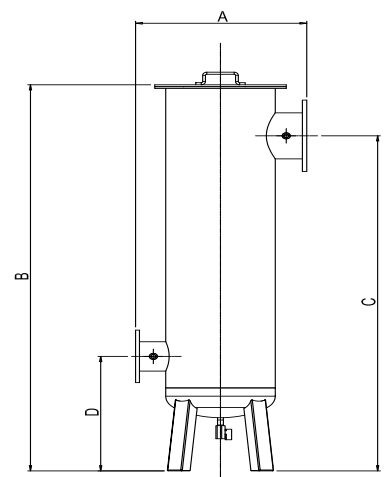

\*Nominal working conditions: gas inlet temperature 40 °C, atmospheric pressure, 60 %CH<sub>4</sub> 40 %CO<sub>2</sub>, pressure drop 3 mbar. FFB Filters can work at higher gas flow rates with an increase in pressure drop (refer to Parker Hiross)

## **Granzow AB - svensk tryckluftspartner**

Granzow AB är idag en av de tre största aktörerna inom tryckluftsteknik på den svenska marknaden. Vår position är understödd av några av de marknadsledande tillverkarna av kompressorer och luftbehandlingsutrustning.



### **ISO 14001**

Granzow service är certifierad enligt ISO 14001 vilket medför att kvalitets- och miljötänkande är naturliga faktorer i vårt arbete.

Vi ser som en av våra uppgifter att hålla våra

kunders tryckluftsproduktion igång och samtidigt utföra uppdraget med utgångspunkt från högt ställda kvalitets- och miljökrav.



**Service i hela landet: 020-78 80 00 • [www.granzow.se](http://www.granzow.se)**

**Försäljning: Enköping 0171-47 80 00 • Stockholm 08-744 41 10  
Göteborg 031-21 00 43 • Malmö 040-23 40 53  
Jönköping 036-12 05 06 • Kalmar 0480-49 03 03**



**GRANZOW**  
**svensk tryckluftspartner**

[www.granzow.se](http://www.granzow.se) • Tel 0171-47 80 00

<sup>®</sup>Granzow registrerat varumärke. © 2008