



---

# HYPERCHILL SMART-E

## ECO-FRIENDLY INDUSTRIAL WATER CHILLERS

GSFE Division



# ECO-FRIENDLY INDUSTRIAL WATER CHILLERS FOR PRECISION COOLING

The new Hyperchill Smart-E range is a Green and Eco-Friendly solution, meeting the requirements laid out by the European F-Gas regulation (EU 2024/573), requiring the use of environmentally friendly low GWP refrigerants.



Hyperchill Smart-E has been optimized for operation with R1234ze, a refrigerant with one of the lowest greenhouse effect, thanks to its near zero GWP, with no impact on the ozone layer.

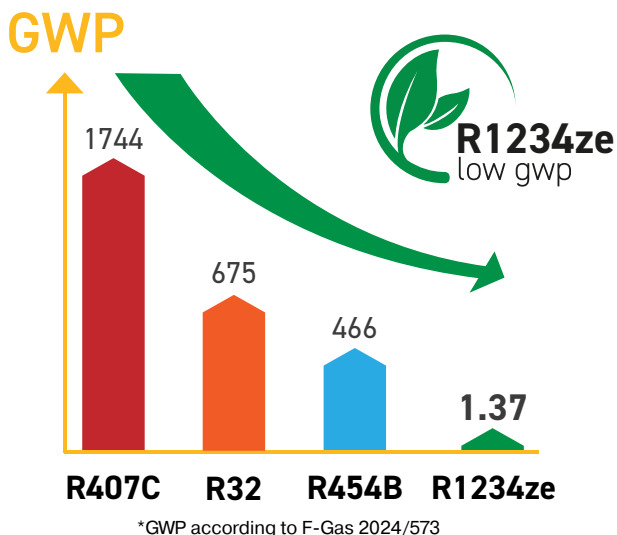

R1234ze belongs to Safety Class A2L (ISO 817, low-toxicity and mildly flammability). However, differently from other refrigerants belonging to A2L category (e.g. R454B and R32), R1234ze is considered as a non-flammable refrigerant for transporting and storage purposes, without any limitations due to flammability.

Extremely compact and easy to use, Hyperchill Smart-E is designed for safe and reliable operation in the most varied working conditions, providing a precise and accurate control of

the process fluid temperature. The availability of a wide range of accessories and options makes Hyperchill Smart-E a flexible solution that fits the needs of industrial applications.

Thanks to its highly efficient and eco-friendly design, combined with extended operating limits, Hyperchill Smart-E ensures reliable and stable working conditions with the lowest power consumption. Improving the efficiency and productivity of the whole industrial process, reducing operating costs with particular care to the environment.

Each individual Hyperchill Smart-E unit is extensively tested to guarantee efficient operation and reliability in all working conditions.

## Process Cooling Applications

- Extruders
- Surface Processing
- Welding Engineering
- Blow Mould Machines
- Printing Systems
- Coating Systems
- Chemical and Pharmaceutical
- Plastics Processing
- Thermoform Machines
- Plasma Coating
- Medical Imaging
- Food and Beverage Industry
- Injection Moulding
- Electroplating Baths
- Biogas and Biomethane Treatment
- Compressed Air
- Hydrogen

# CUSTOMER BENEFITS



SAFETY  
CLASS

- **Very low GWP (1,37) R1234ze refrigerant**, belonging to Safety Class A2L (ISO 817), but considered as a non-flammable refrigerant for transport and storage purposes. Without any extra limitations and costs to customers compared to other A2L and A3 refrigerants.
- **Highly efficient design combined with the Lowest Total Power Consumption**, minimizing customer operating costs, improving efficiency and productivity of the whole industrial process.
- **High performance and reliable components**, ensuring reliable and stable operation, even in extreme ambient conditions, (up to +48°C) and very low water temperature requirements (up to -10°C).
- **User friendly controller with integrated MODBUS RTU and TCP/IP**, ensuring efficient system monitoring.
- **Highly configurable** with a wide choice of options and accessories, featuring internal hydraulic circuit components to fit the needs of process cooling applications, for an easy and plug and play installation.

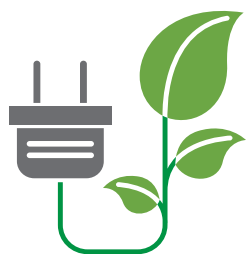

## High Reliability and Performance with the Lowest Energy Consumption

- **Large built-in water tank**, providing a large thermal mass/storage capacity, thus reducing the number of refrigerant compressor stop/starts and short cycling. Thereby increasing the compressor, and chiller lifetime, and reducing the energy consumption.
- **Fan step control and optional fan speed-control (low ambient options)** ensures constant performances at different temperatures, longer lifetime of the fans and a reduction in absorbed power.
- **Water outlet temperature range -10°C/+25°C, and ambient temperature operating range -10°C/+48°C**, ensure reliable operation at different cooling load requirements (additional low ambient temperatures available).
- **Dual refrigerant circuit, multiple scroll compressors** in automatic rotation logic and generous tank size, increase compressor lifetime, efficiency and water temperature stability and control at different cooling loads.
- **Oversized condensers and evaporators** guarantee high performing heat exchange, at extreme ambient conditions, with very high energy efficiency.
- **Proprietary PID controller software**, developed and tested to give the highest temperature consistency at variable loads.

# PRODUCT FEATURES

Complete solution, easy to install and manage

## Microchannel Condenser

(with Long Life Alloy)

- Maximized thermal exchange efficiency
- Reduced refrigerant volume compared to traditional condensers (up to 50%)
- Protective metallic mesh filters (standard up to ICES240E)
- Optional: Epoxy electrophoretic coating (for aggressive ambient conditions)

## Electronic Expansion Valve

- Increased refrigeration circuit stability and efficiency
- Precise and fast reaction to different cooling loads/ ambient temperature variations



## Dual Independent Refrigerant Circuit

(with Multiple Hermetic Scroll Compressors)

- Increased efficiency and water stability at different loads and ambient conditions
- 50% cooling capacity guaranteed in case of a refrigerant circuit failure
- Compressors rotation logic

## Hydraulic Circuit

- Compact design, thanks to the internal hydraulic circuit design with a generously sized water storage tank and pump (up to ICES240E)
- Optional internal buffer tank and pump from ICES320E
- Different pump options

## Robust and Easy Maintenance Design

- IP54 chiller design for safe outdoor installation
- Galvanized carbon steel panels with polyester powder coating
- Refrigeration and hydraulic circuit safety devices
- Independent condensing section
- Full access to internal components

## Axial Fans

- Fan step control and rotation logic
- Optional: Fan speed control for increased efficiency at low ambient temperatures



## Highly Efficient Evaporator

- Optimized design for R1234ze
- Plate heat exchanger in stainless steel (ICES160-200E)
- Shell and tube evaporator (from ICES240E)

## Electrical Cabinet

- User friendly controller with proprietary software
- Integrated MODBUS RTU and TCP/IP

## Technical Specifications

Model		ICES160E	ICES200E	ICES240E	ICES320E	ICES400E	ICES470E	ICES580E
Nominal cooling capacity <sup>1</sup>	kW	161,2	187,5	236,2	320,3	390,2	472,8	586
Nominal total absorbed Power <sup>1</sup>	kW	31,7	41,1	52,6	68,1	78,9	103,4	123,4
EER <sup>1</sup>		5,09	4,56	4,49	4,70	4,94	4,57	4,75
SEPR HT <sup>2</sup>		5,8	5,29	5,20	5,45	5,58	5,31	5,50
Cooling capacity <sup>3</sup>		112,2	130,3	165,0	224,5	272,4	330,2	414,9
Total absorbed power <sup>3</sup>		35,2	44,8	57,0	74,3	86,4	111,8	133,0
EER <sup>3</sup>		3,19	2,91	2,89	3,02	3,15	2,95	3,12
Power supply	V/ph/Hz	400 / 3 / 50						
Electrical protection class		IP54						
Refrigerant		R1234ze						

### Compressor

Type		Scroll						
Compressors/circuit		2 / 2			4 / 2			

### Axial Fans

Quantity	n.°	2	3	4	6	8
Condenser Air flow	m <sup>3</sup> /h	39959	57702	76889	115333	153778

### Pump P30 (optional from size ICES320E)

Water flow (nom./ max) <sup>6</sup>	m <sup>3</sup> /h	27,6/42	32,1/42	40,4/42	55,3/72	66,8/72	80,9/132	100,2/138
Head pressure (nom./max) <sup>6</sup>	m H <sub>2</sub> O	33/27	31/27	29/27	33/27	28/27	28/17	30/20

### Weights and Dimensions

Width	mm	1400	1400	1400	2150	2150	2150	2150
Depth	mm	3540	3540	3540	3500	3500	3500	4580
Height	mm	2220	2220	2220	2480	2480	2480	2480
Water connections inlet/outlet	in	2½"	2½"	2½"	Victaulic DN100 4"	Victaulic DN100 4"	Victaulic DN100 4"	Victaulic DN100 4"
Total water storage capacity (with tank)	ltr	950	950	950	500	500	500	500
Weight <sup>4</sup>	kg	1600	1800	1850	2530	2880	3200	4000

### Noise Level

Sound pressure <sup>5</sup>	dB(A)	62	62	65	65	65	68	68
-----------------------------	-------	----	----	----	----	----	----	----

1) **Nominal conditions:** water inlet 20°C/outlet 15°C, ambient 25°C, glycol 0% (according to EN 14511).

2) Value calculated in accordance with the European regulation (EU) 2016/2281 with regards to Ecodesign requirements for high temperature process chillers.

3) **Rating conditions:** water inlet 12°C/outlet 7°C, ambient 35°C, glycol 0% (according to EN14511-2).

4) Includes refrigerant charge and pallet (version without options and accessories).

5) **Sound pressure:** average value obtained in free field on a reflective surface at a distance of 10 m from the condensate side of the machine and at a height of 1.6 m from the unit support base. Values with tolerance ± 2 dB. The sound levels refer to operation of the unit under full load in nominal conditions.

6) Values declared according to pump supplier; max flow and head pressure depends on working condition and internal chiller pressure drop.

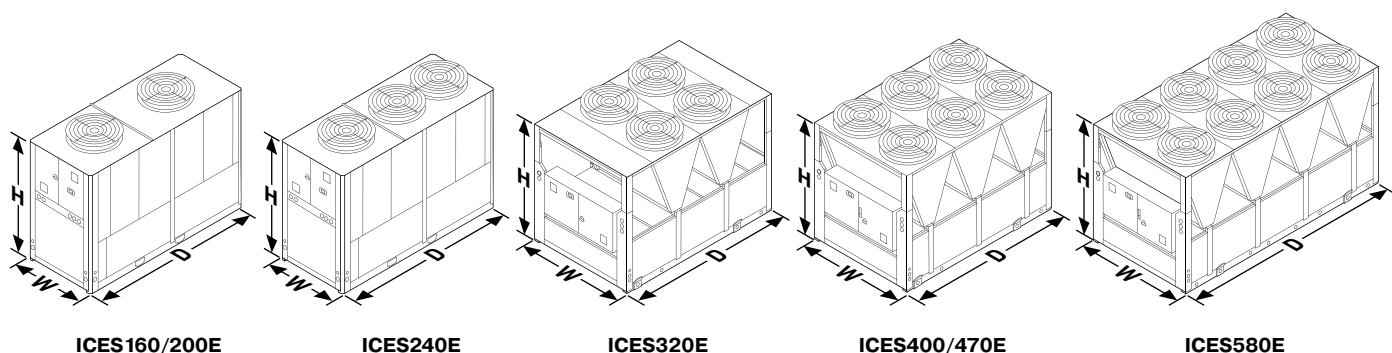

ICES160/200E

ICES240E

ICES320E

ICES400/470E

ICES580E

## Options and Standard Features

✓ = Option ● = Standard Feature

Model	ICES160E	ICES200E	ICES240E	ICES320E	ICES400E	ICES470E	ICES580E
MODBUS RTU / TCP IP	●	●	●	●	●	●	●
Differential pressure switch	●	●	●	●	●	●	●
Low ambient -10°C with fan step control	●	●	●	●	●	●	●
Low water temperature up to -10°C	●	●	●	●	●	●	●
Hydraulic circuit with water storage tank and 3 bar pump	●	●	●				
No tank and/or no pump	✓	✓	✓	●	●	●	●
Non ferrous hydraulic circuit	on request	on request					
Buffer tank				✓	✓	✓	✓
P50 (5 bar pump)	✓	✓	✓	✓	✓	✓	✓
P30 (3 bar pump)	●	●	●	✓	✓	✓	✓
P15 (1.5 bar pump)	✓	✓	✓	✓	✓	on request	on request
Dual pump P30 (3 bar pump)	✓	✓	✓	✓	✓	✓	✓
Dual pump P50 (5 bar pump)	✓	✓	✓	✓	✓	✓	✓
BioEnergy and aggressive ambient protection	✓	✓	✓	✓	✓	✓	✓
Anti-freeze heating	✓	✓	✓	✓	✓	✓	✓
Low ambient -20°C	✓	✓	✓	✓	✓	✓	✓
Low ambient -30°C (with control panel cover)	on request	on request	on request	on request	on request	on request	on request
Compressor hoods	on request	on request	on request	on request	on request	on request	on request

## Versions

Model	ICES160E	ICES200E	ICES240E	ICES320E	ICES400E	ICES470E	ICES580E
Air Cooled	✓	✓	✓	✓	✓	✓	✓
Water Cooled	✓	✓	✓				
Low Noise	on request	on request	on request	on request	on request	on request	on request

## Accessories

<b>Water fill kits:</b>	Pressurized fill kit with expansion tank for all models with water tank included, automatic or ambient manual kits for models up to ICES240E.
<b>Remote control advanced kits:</b>	Complete remote monitoring of the unit, including “master/slave” functioning.
<b>Manual External Bypass with PRV valve:</b>	Externally manually adjustable allowing the correct flow through the system to be set.
<b>Control panel cover:</b>	Can be supplied already installed or loose.
<b>Metallic mesh filters:</b>	For condenser module protection.

## Service & underhåll

En viktig del i vårt koncept som totalleverantör och partner, är att kunna erbjuda kvalificerad specialhjälp för tillsyn, service och underhåll av kompressorer, tryckluftsanläggningar och gasgeneratorer. Genom att teckna serviceavtal med oss, kommer kvalificerad service, rätta reservdelar, effektiva rutiner och löpande dokumentation att garantera en säkrare drift och användning för att distribuera ren tryckluft och rätt kvävgaskvalitet.



### ISO 14001

Granzow service är certifierad enligt ISO 14001 vilket medför att kvalitets- och miljötänkande är naturliga faktorer i vårt arbete. Vi ser som en av våra uppgifter att hålla våra kunders tryckluftsproduktion igång och samtidigt utföra uppdraget med utgångspunkt från högt ställda kvalitets- och miljökrav.



Rätt kapacitet



Rätt kvalitet



Rätt tryck



Rätt service

# GRANZOW

svensk tryckluftspartner

Service: 020-78 80 00  
Försäljning: 0171-47 80 00  
[www.granzow.se](http://www.granzow.se)